

# LITTLE WONDER®

1028 STREET ROAD, P.O. BOX 38

PHONE 215-357-5110

SOUTHAMPTON, PA 18966

FAX 215-357-8045

**Professionals Demand Little Wonder, Shouldn't You?**

OPERATING, ASSEMBLY INSTRUCTIONS AND PARTS LIST FOR  
EDGER TRIMMERS CATALOG #5002, #6002, #6002 I/C, # 6002K  
AND EDGERS CATALOG #6032, #6032 I/C, #6032K



## IMPORTANT SAFETY INSTRUCTIONS

**▲ WARNING ▲** To Avoid Injury — when using your Edger or Edger Trimmer, follow basic precautions, including the following:

1. READ THESE IMPORTANT SAFETY INSTRUCTIONS, THE OPERATING INSTRUCTION, ASSEMBLY INSTRUCTION, USER MAINTENANCE INSTRUCTIONS, AND THE BRIGGS AND STRATTON OR KAWASAKI OPERATING AND MAINTENANCE INSTRUCTIONS CAREFULLY AND COMPLETELY. Be thoroughly familiar with the controls and the proper use of the equipment. Know how to stop the unit and disengage the controls quickly. SAVE MANUALS AND INSTRUCTIONS AND KEEP IN A SAFE PLACE.

2. **▲ DANGER ▲** — ROTATING BLADE

- Keep both hands on handles when blade is rotating.
- Keep feet away from cutting area.
- Do not attempt to remove cut material or hold material to be cut when engine is running or when blade is moving.
- Make sure spark plug wire is disconnected when clearing jammed material from blade or cutter head.

- CAUTION - Blade coasts after turn off.

3. **▲ WARNING ▲** DO NOT USE MACHINE ON GRAVELED SURFACES. Thrown objects can cause serious injuries and/or property damage.

4. KEEP OPERATING AREA CLEAR - Keep the area of operation clear of all persons and pets.

5. USE EDGER OR EDGER TRIMMER PROPERLY — Use only for edging or trimming the type of shrub, growth and the like described in the operating instructions. Do not abuse machine. Do not use in rain or wet locations.

6. DON'T OVERREACH OR STAND ON UNSTABLE SUPPORT — Keep good footing and balance at all times.

7. **▲ DANGER ▲** NEVER DIRECT DISCHARGE OF MATERIAL TOWARD BYSTANDERS OR ALLOW ANYONE NEAR THE AREA OF OPERATION. Use care in directing discharge to avoid glass enclosures, automobiles, and the like.

8. **▲ DANGER ▲** OBJECTS STRUCK BY THE BLADE CAN CAUSE SEVERE INJURIES TO PERSON. The lawn should always be carefully examined and cleared of all objects prior to use.

9. STAY ALERT FOR UNEVEN SIDEWALKS, HOLES IN TERRAIN OR OTHER SIMILAR CONDITIONS. Always push slowly over rough ground.

10. NEVER OPERATE MACHINE WITHOUT GOOD VISIBILITY OR LIGHT.

11. STAY ALERT — Watch what you are doing - use common sense. Do not operate product when fatigued or under the influence of alcohol or drugs.

12. DRESS PROPERLY — Wear safety glasses or goggles. Do not wear loose clothing or jewelry. They can be caught in moving parts. Use of sturdy gloves and safety footwear is recommended. Always wear pants that cover legs.

13. DISCONNECT (UNPLUG) SPARK PLUG LEAD —

- When not in use.
- Before servicing, cleaning and the like.
- Before changing blade, belt, etc.

14. MAINTAIN PRODUCT WITH CARE — Follow maintenance instructions given in Manuals.—To reduce the risk of fire, do not allow excessive grass, leaves, or grease to accumulate on the machine.

15. STORE MACHINE INDOORS — When not in use, store indoors in a dry place, locked or otherwise inaccessible to children.

16. DO NOT ATTEMPT TO REPAIR MACHINE — Have repairs made by qualified dealer or repairman.—Use only original Little Wonder replacement parts.

17. HANDLE GAS WITH CARE; IT IS HIGHLY FLAMMABLE.

- a) Use a gas container acceptable for the purpose and do not store gas in a house.
- b) Never add gas to a running or hot engine.
- c) Fill gas tank outdoors with extreme care. Never fill gas tank indoors.
- d) Replace gas cap securely
- e) If gas is spilled, move Edger and gas container from area and do not create a source of ignition.

18. **▲ CAUTION ▲** — To reduce the risk of fire, replace gasoline cap securely.

19. START THE ENGINE CAREFULLY. Keep hands, feet, clothing and the like well away from blade and moving parts.

20. DO NOT RUN THE ENGINE INDOORS; exhaust fumes are dangerous.

21. NEVER ATTEMPT TO MAKE ADJUSTMENTS — while the engine is running, except to carburetor.

**22. IF BLADE STRIKES A FOREIGN OBJECT, FOLLOW THESE STEPS:**

- a) Stop engine.
- b) Disconnect spark plug lead.
- c) Inspect for damage.
- d) Repair any damage before restarting and operating the machine.

**23. DISENGAGE THE BLADE AND/OR STOP THE ENGINE WHEN THE MACHINE IS TRANSPORTED OR NOT IN USE.**

**24. STOP THE ENGINE WHEN LEAVING THE MACHINE UNATTENDED.**

**25. WHEN CLEANING, REPAIRING, OR INSPECTING,** make certain the blade and all moving parts have stopped. Disconnect the spark plug wire, and keep the wire away from the plug so that unintentional starting does not occur.

**26. NEVER OPERATE THE MACHINE** without guards or other protective devices in place. Before each use, check all fasteners and safety devices for proper function.

**27. DO NOT OPERATE** — with a damaged or excessively worn blade.

**28. MULTIPLE OPERATORS** — Keep a safe distance between two or more operators when working together simultaneously.

**29. BE SURE MACHINE IS FULLY ASSEMBLED** — Never operate without all guards and deflectors in place. Ensure that all nuts, bolts, screws are installed and properly tightened. Check pulley set screws and all fasteners for tightness and lubricate cutter head shaft, key, keyway and bushings with light oil prior to each use.

**30. ALWAYS KEEP THE THROTTLE IN THE "STOP" POSITION WHEN NOT IN USE.**

**31. LABELS SHOULD BE INSPECTED BEFORE EACH USE.** Replace damaged labels immediately. See figure #5.

**ASSEMBLY INSTRUCTIONS**

Your Little Wonder Edger or Edger Trimmer requires a minimal amount of assembly prior to use.

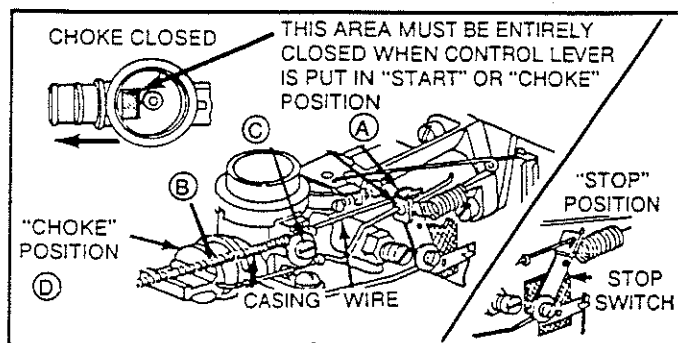
Packed with each unit you will find the following:

1. Edger or Edger Trimmer assembly consisting of engine mounted on deck with wheels and cutter head installed.
2. Upper Handle assembly.
3. Blade Guard, P/N 129B
4. Indexing Rod, P/N 165-2, Deluxe Model, Catalog #6002, 6002, and 6002K only.
5. Draw Rod P/N 198, Model #6002, 6002, 6002K, 6032, 6032, 6032K only.
6. Blade, P/N 129
7. One (1) bag of hardware and fasteners containing the following:

QTY.	P/N	DESCRIPTION
2	129C-1	Hex Head Cap Screw $\frac{5}{16}$ - 18 x $\frac{1}{2}$ " lg.
2	129D	Lockwasher $\frac{5}{16}$
4	144-2	Hex Head Cap Screw $\frac{1}{4}$ -20 x 1 $\frac{1}{8}$ " lg.
1	146B	Throttle Clip
2	163	Washer - Flat $\frac{5}{16}$
4	972	Nut, Lock $\frac{1}{4}$ -20
1	973	Nut, Lock 10-32
1	208	Bolt, Hex Head 10-32 x $\frac{3}{4}$ "

**STANDARD EDGER TRIMMER, CATALOG #5002 REFER TO PARTS EXPLOSION AND ILLUSTRATION AND ASSEMBLE YOUR EDGER TRIMMER AS FOLLOWS:**

1. Use the four cap screws, P/N 144-2 and nuts, P/N 972 to assemble the handle to the main Edger Trimmer as illustrated.
2. After assembling upper handle to Edger Trimmer, you must connect throttle to engine. Refer to figure #4 below for throttle connection to Briggs and Stratton engine and connect throttle as follows:
  - a) Place throttle control lever in CHOKE position,
  - b) Loosen screw on top of air cleaner and rotate cleaner 180°, to allow access to throttle linkage on engine.
  - c) Take throttle control wire to engine on the muffler side. Bend in front of rotated air cleaner, and feed throttle wire through.
  - d) Lift throttle control B over air cleaner case and place in clamp at point C.
  - e) Pull the throttle control cable until you reach the CHOKE position at point D, then tighten bolt at point C.
  - f) Rotate air cleaner case 180° to original position and tighten screw on top of air cleaner.
  - g) Secure throttle cable to handle with cable clamp P/N 146B.
  - h) Move throttle lever on handle brace to make sure mechanism is functioning properly between CHOKE and STOP position.
  - i) Start, run, and stop engine to be sure connection is correct.
  - j) Additional adjustments and instructions are found in Briggs & Stratton operating and maintenance instructions packed with unit.

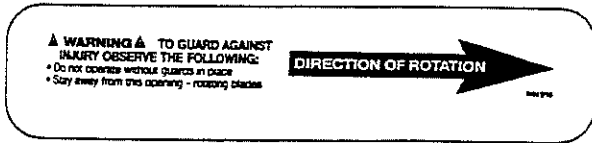


**Figure 4. THROTTLE CONNECTION MODEL #5002**

3. Install cap screw, P/N 208 and nut, P/N 973 to secure the adjusting rod lower, P/N 155C to adjusting rod upper, P/N 155 as illustrated.
  4. The blade guard, P/N 129B must be installed on the flange of the cutter head, P/N 126. Place flat washers, P/N 163 against outside surface of blade guard. Place lock washer, P/N 129D under head of cap screw, P/N 129C-1. Screw cap screws into tapped holes in flange of cutter head. Location of blade guard should be adjusted so the bottom of the guard just clears the ground when edging. Set to the desired position and tighten cap screws.
  5. Remove nut, P/N 130 and ONE washer, P/N 128 and install blade, P/N 129. Replace washer and nut and tighten. Be sure to install washers with flat side against blade.
  6. Rotate mud flap, P/N 209 to a position directly behind and perpendicular to blade guard, P/N 129B. Tighten nut, P/N 114B, and cap screw P/N 129C to secure mud flap to Edger Trimmer.
- YOUR STANDARD EDGER TRIMMER, CATALOG #5002, IS NOW ASSEMBLED.**

# SAFETY DECAL IDENTIFICATION

(1)



P/N 210

(2)



P/N 211

(3)



P/N 4036

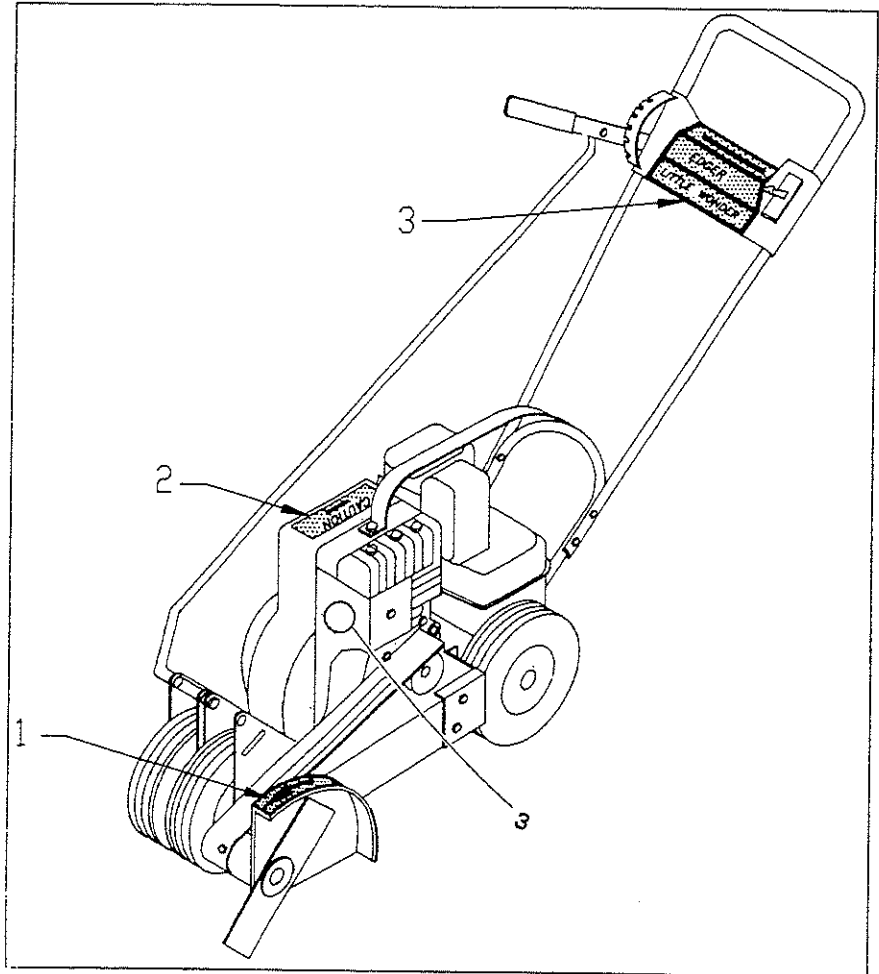
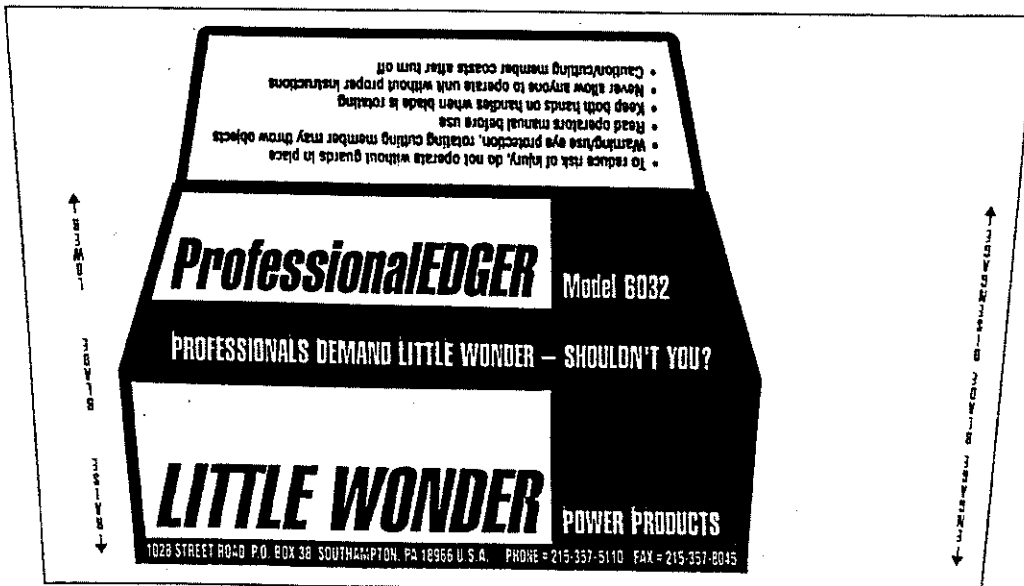


Figure 5.

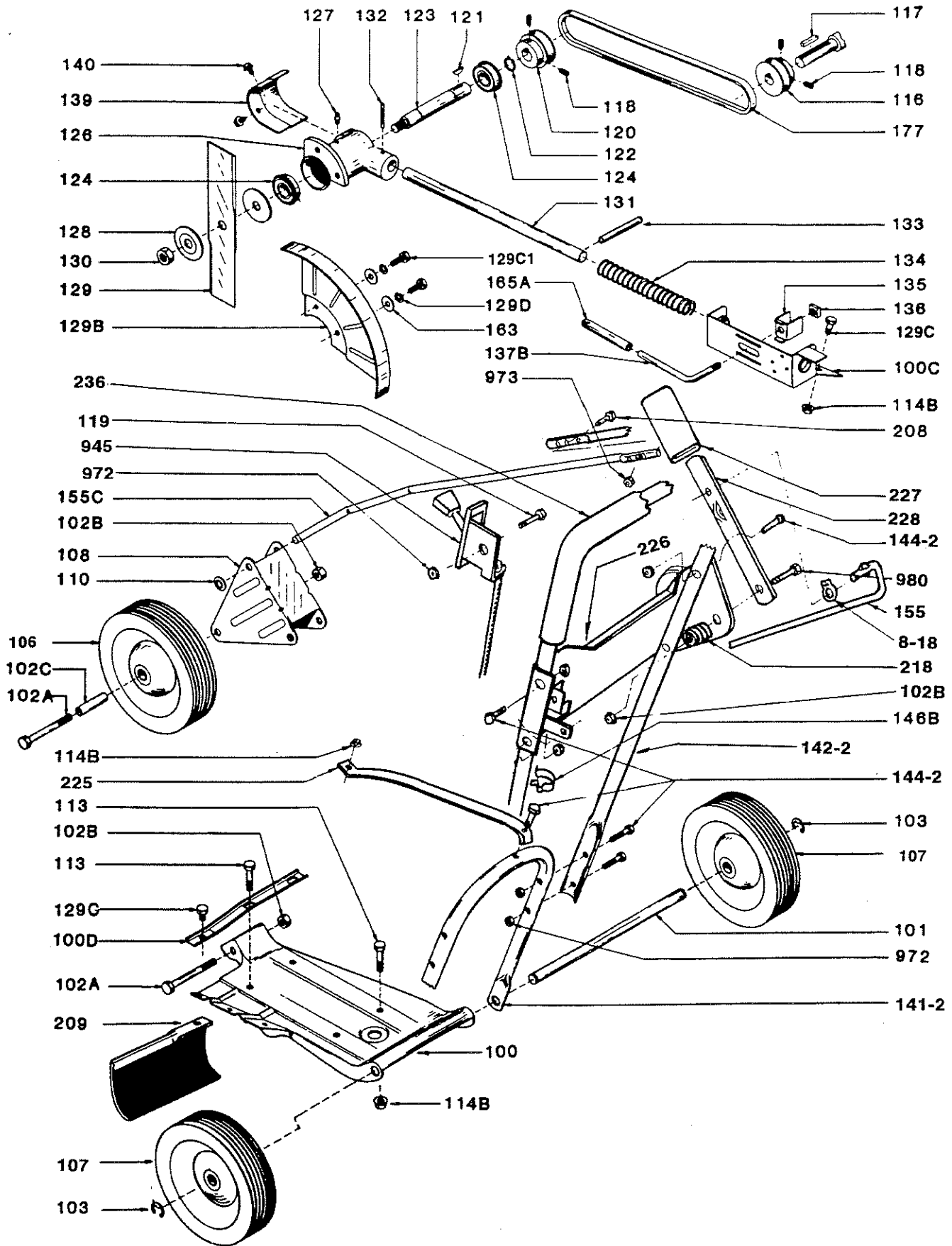
## (4) Brace Label



## Brace Label Identification

Description	P/N
Model 5002	229
Model 6002	230
Model 6002I/C	231
Model 6002K	232
Model 6032	233
Model 6032I/C	234
Model 6032K	235

# STANDARD MODEL EDGER TRIMMER - CATALOG #5002



**DELUXE MODEL #6002, #60021/c, #6002K**

**ASSEMBLY OF DELUXE EDGER TRIMMER  
CATALOG #6002, 60021/C 6002K**

REFER TO PARTS EXPLOSION AND ILLUSTRATION FOR DELUXE MODELS AND ASSEMBLE YOUR EDGER TRIMMER AS FOLLOWS:

1. Insert index rod, P/N 165-2 through hole in bracket A, P/N 166 of handle assembly, as shown in Deluxe Figure 1, and lower to its bottom position. Insert index rod, P/N 165-2 into gear B, P/N 160A on main Edger Trimmer assembly as shown in Deluxe Figure 2.

**STEP #1 MUST BE DONE PRIOR TO  
PROCEEDING WITH STEP #2**

2. Use the four cap screws, P/N 144-2 and nuts, P/N 972 to assemble the handle to the main Edger Trimmer assembly.

3. Refer to page 7, item 2, illustrations B and C, for procedures to connect throttle control to engine.

4. Tighten cap screw, P/N 208 and nut, P/N 973 to secure the adjusting rod lower, P/N 155C to the adjusting rod upper, P/N 155 as illustrated in figure 3.

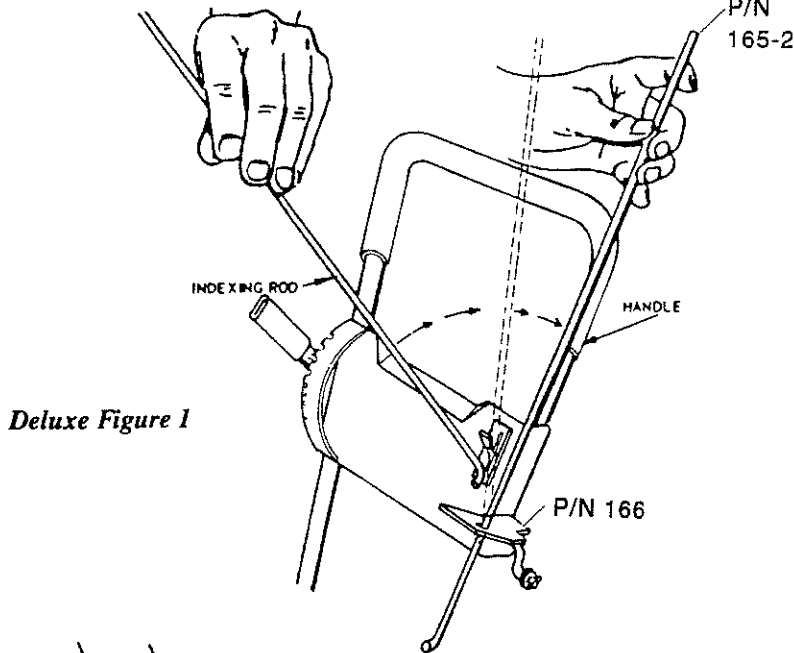
5. Assemble draw rod, P/N198 as shown in Deluxe Figure 3. Remove cotter pin P/N 156 and washer, P/N 163 from belt slackener lever, P/N167-2, located on upper hand. Place elongated looped in draw rod on belt slackener lever. Reinstall washer and cotter pin, and bend legs of cotter pin. Remove cotter pin, P/N 156 and clevis, P/N 170 from belt slackener, P/N 169. Place round hole in draw rod between legs of belt slackener. Reinstall clevis pin thru belt slackener and draw rod. Replace and bend cotter pin.

6. The blade guard, P/N 129B must be installed on the flange of the cutter head, P/N 126. Place flat washers, P/N 163 against outside surface of blade guard. Place lock washer, P/N 129D under head of cap screw, P/N 129C-1. Screw cap screws into tapped holes in flange of cutter head. Location of blade guard should be adjusted so the bottom of the guard just clears the ground when edging. Set to the desired position and tighten cap screws.

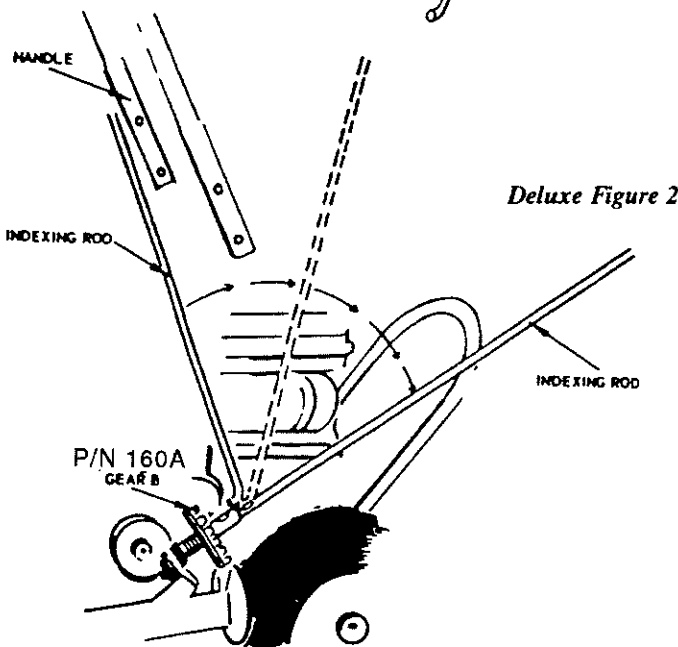
7. Remove nut, P/N130 and ONE washer, P/N128 and install blade, P/N129. Replace washer, nut, and tighten. Be sure to install washers with flat side against blade.

8. Rotate mud flap, P/N 209, to a position directly behind, and perpendicular to, blade guard, P/N 129B. Tighten nut P/N 114B, and cap screw P/N 129, to secure mud flap to Edger Trimmer.

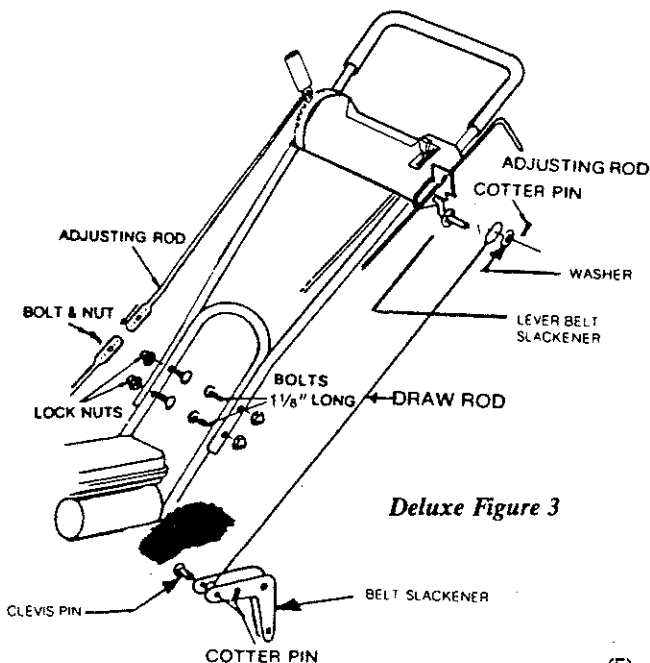
**YOUR DELUXE EDGE TRIMMER,  
CATALOG #6002, #6002 I/C, #6002K,  
IS NOW ASSEMBLED.**



*Deluxe Figure 1*

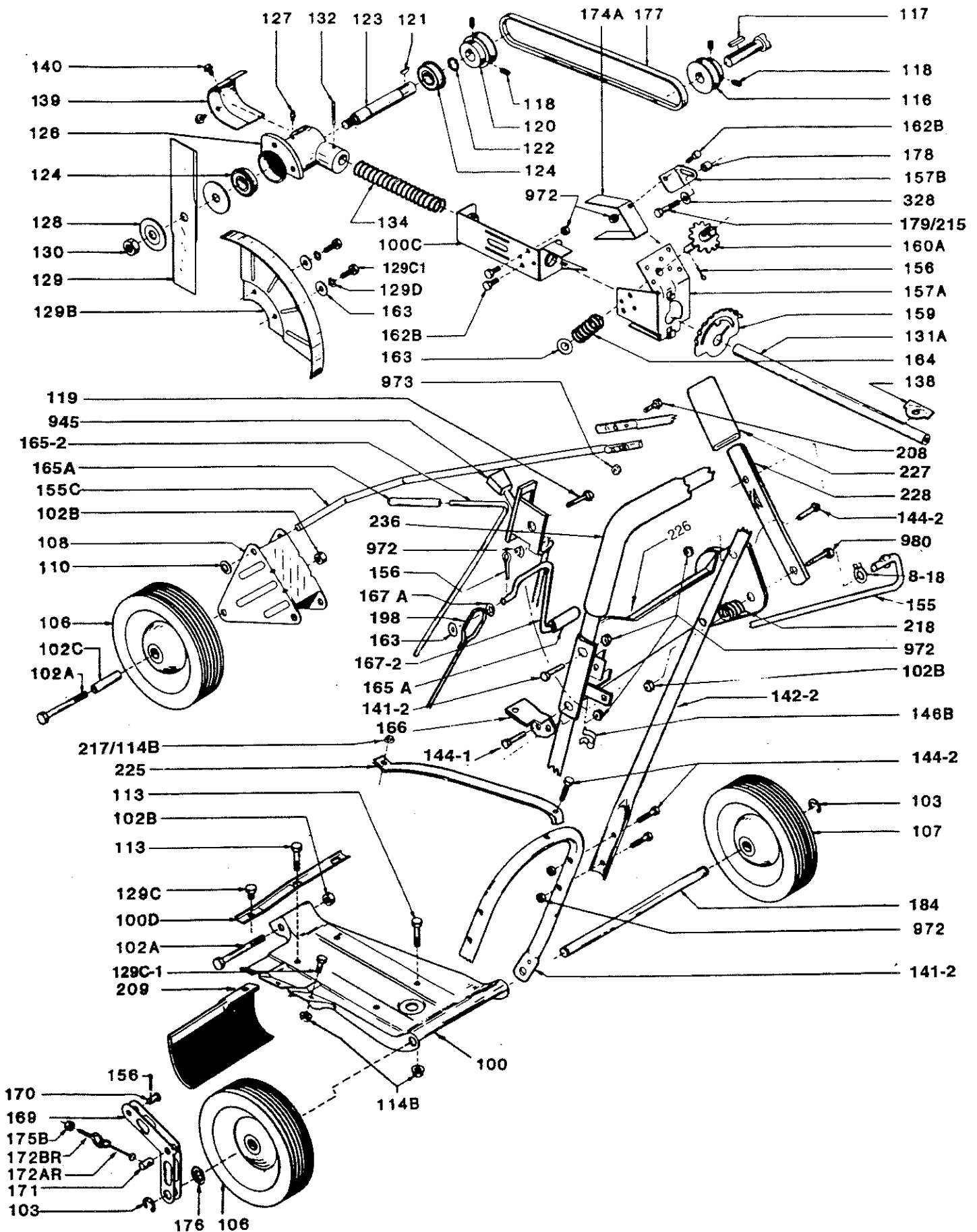


*Deluxe Figure 2*



*Deluxe Figure 3*

# DELUXE MODEL EDGER TRIMMER - CATALOG #6002, 6002 1/2c, 6002K



**ASSEMBLY OF PRO EDGER  
CATALOG #6032,60321/C, 6032K**

REFER TO PARTS EXPLOSION AND ILLUSTRATION AND ASSEMBLE YOUR PRO EDGER AS FOLLOWS:

1. Use the four cap screws, P/N 144-2 and nuts, P/N 972 to assemble the handle to the main Edger Trimmer assembly.

2. After assembling upper handle to Edger, you must connect throttle control to engine.

**A. Refer to figure #6 for throttle connection to Briggs and Stratton engine and install throttle as follows:**

- a) Set throttle control lever mounted on handle brace to FAST position.
- b) Place your finger under and behind cover panel and lift linkage at point C. This moves connecting point B forward.
- c) Feed wire on throttle control through hole in linkage at point B.
- d) Place throttle cable in clamp at point A. Pull throttle cable until the slightest resistance is felt (just before choke lever moves). Then tighten bolt at point A.
- e) Secure throttle cable to handle with throttle cable clamp, P/N 146B.
- f) Move throttle lever handle brace to make sure mechanism is functioning properly between CHOKE and STOP position.
- g) Start, run and stop engine to be sure your connection is correct.
- h) Additional adjustments and instructions are found in the Briggs & Stratton operating and maintenance instructions packed with unit.

**B. Refer to figure #7 for throttle connection to Kawasaki engine and install throttle as follows:**

- a) Set throttle lever mounted on handle brace to FAST position.
- b) Feed wire on throttle control through hole in linkage at point A.
- c) Place throttle in clamp at point B. Pull throttle cable until the slightest resistance is encountered, then tighten bolt at point B.
- d) Secure throttle cable to handle with throttle cable clamp, P/N 146B.
- e) Move throttle lever on handle brace to make sure mechanism is functioning properly between CHOKE and STOP position.
- f) Start, run and stop engine to be sure your connection is correct.
- g) Additional adjustments and instructions are found in the Kawasaki operator's handbook packed with unit.

3. Tighten cap screw, P/N 208 and nut, P/N 973 to secure the adjusting rod lower, P/N 155C to the adjusting rod upper, P/N 155 as illustrated.

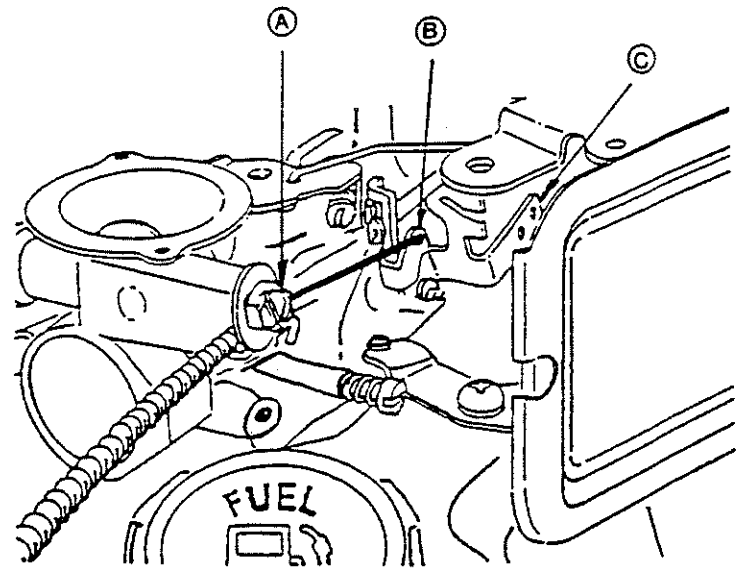
4. Assemble draw rod, P/N 198 as shown in Deluxe Figure 3 (page 5). Remove cotter pin, P/N 156 and washer, P/N 163 from belt lever slackener, P/N 167-2, located on upper handle. Place elongated loop in draw rod on belt slackener lever. Reinstall washer and cotter pin and bend legs of cotter pin. Remove cotter pin, P/N 156 and clevis pin, P/N 170 from belt slackener, P/N 169. Place round hole in draw rod between legs of belt slackener. Reinstall clevis pin thru belt slackener and draw rod. Replace and bend legs of cotter pin.

5. The blade guard, P/N 129B must be installed on the flange of the cutter head, P/N 126. Place flat washers, P/N 163 against outside surface of blade guard. Place lock washer, P/N 129D under head of cap screw, P/N 129C-1. Screw cap screws into tapped holes in flange of cutter head. Location the blade guard should be adjusted so the bottom of the guard just clears the ground when edging. Set to the desired position and tighten cap screws.

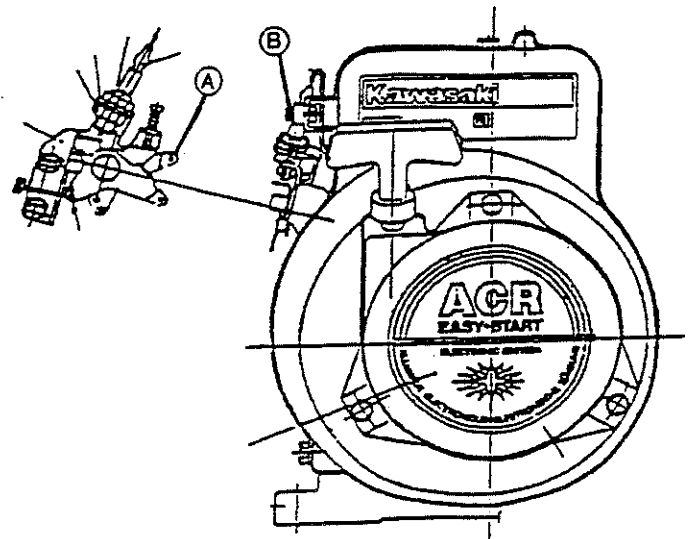
6. Remove nut, P/N 130 and one washer, P/N 128 and install blade, P/N 129. Replace washer, nut and tighten. Be sure to install washers with flat side against blade.

7. Rotate mud flat, P/N 209 to position directly behind, and perpendicular to, blade guard, P/N 129B. Tighten nut P/N 114B, and cap screw, P/N 129C to secure mud flap to Edge Trimmer.

**YOUR PRO EDGER, CATALOG #6032, #60321/C, #6002K IS NOW ASSEMBLED.**

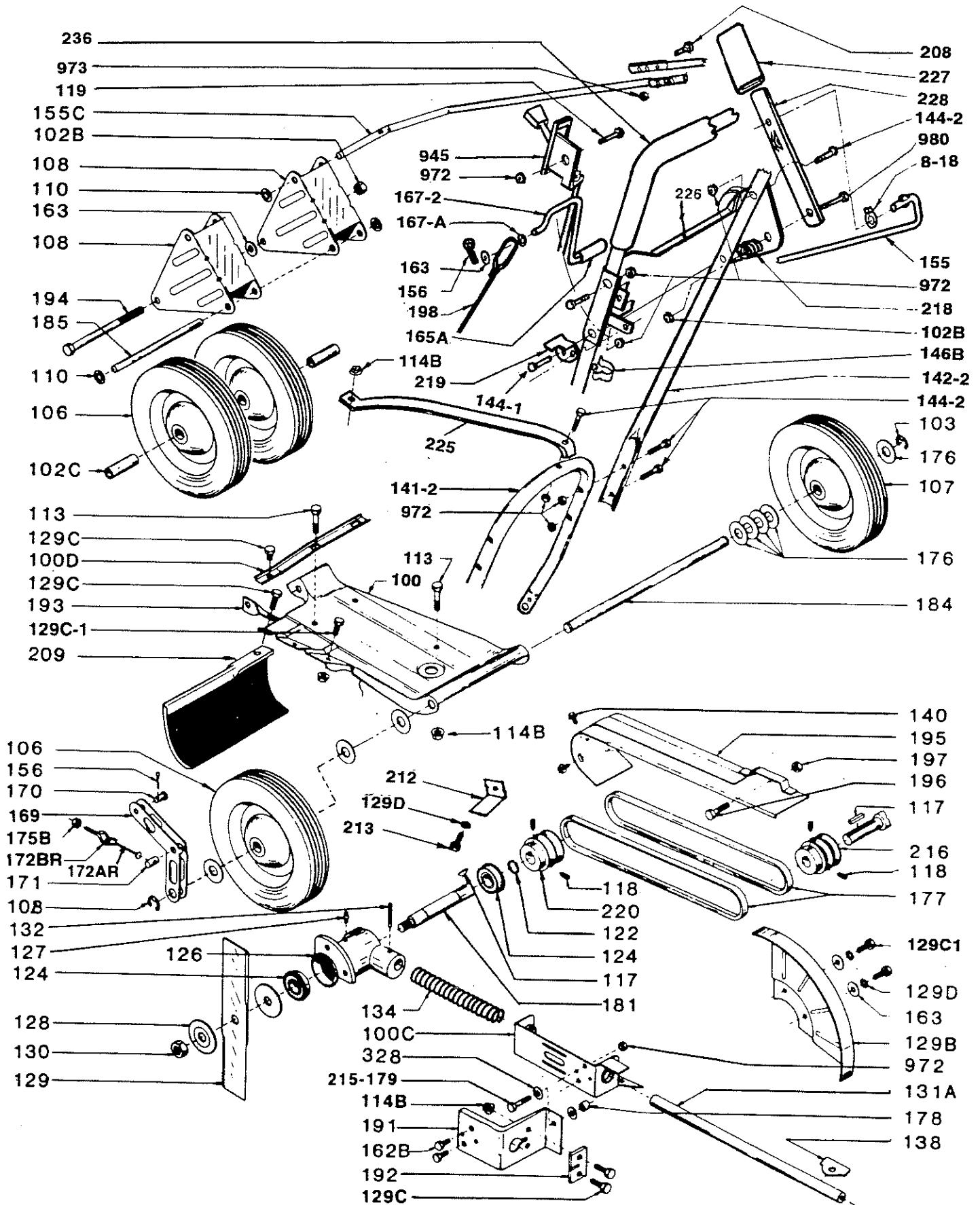


**Figure 6. THROTTLE CONNECTION  
MODEL 6002, 6002 I/C, 6032 & 6032 I/C**



**Figure 7. THROTTLE CONNECTION  
MODEL 6002K & 6032K**

**PRO MODEL EDGER - CATALOG #6032, 60321/c, 6032K**





## OPERATING INSTRUCTIONS

### A. BEFORE STARTING

1. Place Edger or Edger Trimmer on level surface, be sure blade is not obstructed and the area is clear and free of bystanders. Your Edger Trimmer is equipped with a Briggs & Stratton or Kawasaki 4 cycle engine.

2. Check oil level, be sure crankcase is filled with oil.

3. Fill gas tank with fresh gas. Do not mix gas with oil.

**NOTE:** Refer to Briggs & Stratton or Kawasaki Operating and Maintenance Instructions for recommended grades of oil and gas.

### B. STARTING PROCEDURE

1. Your machine is equipped with a Choke-a-Matic throttle control. To start, move lever on throttle control as far forward as possible to CHOKE position.

**NOTE:** A warm engine requires less choking than a cold engine.

2. For Deluxe & Pro models — remove belt tension by pulling the belt slackener lever. P/N 167-2, up. This provides easier starting.

3. Hold the handle of machine with your left hand and pull the rewind starter grip with your right hand.

4. Once engine starts, set throttle control lever to desired speed.

### C. STOP PROCEDURE

1. Pull throttle lever toward you to STOP position.

### D. CAUTION

1. Do not change the engine governor settings or overspeed the engine.

2. If the product vibrates abnormally, immediately stop the engine and check for the cause. Vibration is generally a warning of trouble.

3. Stop the engine whenever you leave the operating position; disconnect the spark plug lead wire before unclogging the cutting member guard, when making a repair, adjust inspection, or the like.

4. Operate machine from position where guards block the line of sight to the cutting member.

### E. OPERATING

1. Eye protection must be worn at all times. Use common sense and exercise caution at all times when operating your Edger or Edger Trimmer.

2. Operate in a safe manner. When edging and trimming the potential exists for thrown objects which can cause injury (i.e.) from rocks, cement, pieces of steel, glass, etc. These obstructions should be avoided at all times.

3. Never leave the machine when the engine is running, particularly on hills where the unit might roll.

4. Setting depth of blade. (1) Place left hand on upper handle. (2) Grasp lever, P/N 228 with right hand and pull to the right, which disengages lever from ratchet segment on handle. Move lever forward or backward along ratchet segment and insert key on lever into notch on ratchet at the desired depth. Moving lever forward decreased depth of cut, moving lever backward increases depth of cut.

5. Setting cutter head angle for Standard model Cat. #5002: (1) Disconnect lead wire from spark plug; be sure machine is not running. (2) Raise blade as described above, (3) Grasp the head shaft handle, P/N 133, with your right hand, grasp lock screw, P/N 137B with your left hand and loosen. Entire cutter head assembly will move freely. Set cutter head to desired angle and retighten lock screw, P/N 137B.

6. Setting cutter head angle for Deluxe model 6002, 6002I/C, 6002K: (1) Remove tension from belt by grasping belt slackener lever, P/N167-2 and rotate towards you to stop position. Wait until blade has stopped rotating. (2) Grasp handle of adjusting rod, P/N165-2 and pull toward you approximately 3/16". Turn handle to either the right or the left to achieve desired cutter blade position. Release indexing rod so the index gear assembly, P/N160A engages and locks in 1 of 9 positions on index gear bracket, P/N157A. Rotate belt slackener lever, P/N167-2 to lower position to engine belt.

7. Engine speed — The engine speed should be kept to the minimum consistent with the job at hand. Speeds higher than necessary will only cause undue wear and tear. A speed halfway between "fast" and "slow" is normally adequate. Tougher jobs may require higher speeds.

8. Little Wonder Edgers and Edger Trimmers provide the finishing touch. They edge at any angle along flower beds, terraces, sidewalks and curbs. They trim along buildings, trees, walks, marker, hedges and fences with ease and reliability.

9. Edging — The blade should be perpendicular to the ground or sidewalk. The cutting depth should be sufficient to cut away the root system, usually 1 to 1 1/2" deep. Along flush sidewalks or driveways, it is easier to place the wheels on the sidewalk or driveway rather than the grass. The hardened tool steel blade, P/N 129 becomes it's own guide if it's permitted to rub against the side or edge of the sidewalk or driveway. Angles other than vertical may be desirable when edging flower beds, walls, posts, etc. When edging along a curve, the rear wheels should be held off the ground so the machine may be maneuvered "wheelbarrow fashion."

10. Trimming — The blade should be placed in a horizontal position. Sometimes, experience and imagination will dictate angles somewhat different than horizontal to accommodate particular conditions. The blade will cut best if it is set as close as possible to the ground without undue scalping problems.

---

## USER MAINTENANCE INSTRUCTIONS

1. Keep all nuts, bolts and screws tight.

2. Never store the machine with fuel in the fuel tank inside a building where fumes may reach an open flame or sparks, or in a confined space such as a car trunk.

3. Always refer to the instruction manual for important details if the product is to be stored for an extended period.

4. Check tightness of blade nut before each use.

5. Prior to each use, lubricate cutter head shaft, key, keyway and bushings with good grade of light oil.

6. Prior to each use, check to see that set screws on pulleys are tight, and guards are in place.

**CAUTION** — Loose set screws can cause damage to shaft and pulley. Improper maintenance could void warranty.

**WARNING:** The engine on your Edger or Edger Trimmer is not equipped with a spark arrester and if machine is to be used on any forest covered, brush covered, or grass covered unimproved land, before using on such land a spark arrester must be added to the muffler. The arrester must be maintained in effective working order by the operator. In the State of California the above is required by law (Section 4442 of the California Public Resources Code). Other states may have similar laws. Federal laws apply on federal lands. See your Authorized Briggs & Stratton or Kawasaki Service Center for spark arrester muffler options.

# PARTS LIST

QUANTITY PER UNIT — CATALOG NUMBERS

PART NUMBER	DESCRIPTION	QUANTITY PER UNIT					CATALOG NUMBERS				
		#5002	#6002	#6002 I/C	#6002K	#6032	#6002K	#6032 I/C	#6032K	#6032K	
100	Deck	1	1	1	1	1	1	1	1	1	
100C	Deck Bracket	1	1	1	1	1	1	1	1	1	
100D	Deck Bracket Support	1	1	1	1	1	1	1	1	1	
101	Axle	1	1	1	1	1	1	1	1	1	
102A	Front Bolt 3/8-16 x 3" lg.	2	2	2	2	2	2	2	2	2	
102B	Hex Nut 3/8-16	3	3	3	3	3	3	3	3	3	
102C	Sleeve	1	1	1	1	1	1	1	1	1	
103	Retaining Ring	2	2	2	2	2	2	2	2	2	
106	Wheel - Front and Left Rear	1	1	1	1	1	1	1	1	1	
107	Wheel - Right Rear	2	2	2	2	2	2	2	2	2	
108	Wheel Housing	1	1	1	1	1	1	1	1	1	
110	Speed Nut	1	1	1	1	1	1	1	1	1	
111	3 H.P. Briggs & Stratton Engine (Not Shown)	1	1	1	1	1	1	1	1	1	
112A	3.5 H.P. Briggs & Stratton (Not Shown)	4	4	4	4	4	4	4	4	4	
113	Hex Head Cap Screw 5/16-18x1 1/2	8	8	8	8	8	8	8	8	8	
114B	Flange Nut 5/16-18	1	1	1	1	1	1	1	1	1	
114C	5/16-18 Lock Nut	1	1	1	1	1	1	1	1	1	
116	Pulley—Engine	1	1	1	1	1	1	1	1	1	
117	Key, Pulley 3/16 Square	1	1	1	1	1	1	1	1	1	
118	Set Screw 5/16-18x3/8	4	4	4	4	4	4	4	4	4	
119	Hex Head Cap Screw 1/4-20x 5/8	1	1	1	1	1	1	1	1	1	
120	Pulley — Cutter Head	1	1	1	1	1	1	1	1	1	
121	Woodruff Key #606	1	1	1	1	1	1	1	1	1	
122	Retaining Ring	1	1	1	1	1	1	1	1	1	
123	Cutter Head Shaft	1	1	1	1	1	1	1	1	1	
124	Bearing	2	2	2	2	2	2	2	2	2	
126	Cutter Head	1	1	1	1	1	1	1	1	1	
127	Grease Fitting	1	1	1	1	1	1	1	1	1	
128	Blade Washer	2	2	2	2	2	2	2	2	2	
129	Blade	1	1	1	1	1	1	1	1	1	
129B	Blade Guard	1	1	1	1	1	1	1	1	1	
129C	Hex Head Cap Screw 5/16-18x3/4	1	1	1	1	1	1	1	1	1	
129C1	Hex Head Cap Screw 5/16-18x1/2	5	5	5	5	5	5	5	5	5	
129D	Lock Washer 5/16	2	2	2	2	2	2	2	2	2	
130	Nut 1/2-20	1	1	1	1	1	1	1	1	1	
131	Cutter Head Shaft	1	1	1	1	1	1	1	1	1	
131A	Cutter Head Shaft	1	1	1	1	1	1	1	1	1	
132	Tension Pin 1/4x1 1/4	1	1	1	1	1	1	1	1	1	
133	Head Shaft Handle	1	1	1	1	1	1	1	1	1	
134	Spring	1	1	1	1	1	1	1	1	1	
135	Lock Yoke	1	1	1	1	1	1	1	1	1	
136	Lock Yoke Nut 3/8-16	1	1	1	1	1	1	1	1	1	
137B	Lock Screw	1	1	1	1	1	1	1	1	1	
138	Key-Head Shaft	1	1	1	1	1	1	1	1	1	
139	Cutter Head Belt Guard	1	1	1	1	1	1	1	1	1	
140	Bolt Hex Head 1/4-20x3/8	2	2	2	2	2	2	2	2	2	
141-2	Handle Lower	1	1	1	1	1	1	1	1	1	
142-2	Handle-Upper	1	1	1	1	1	1	1	1	1	
144-1	Hex Head Cap Screw 1/4-20x1 1/4 -	1	1	1	1	1	1	1	1	1	
144-2	Hex Head Cap Screw 1/4-20 x 1 1/8	8	8	8	8	8	8	8	8	8	
146B	Throttle Clip	1	1	1	1	1	1	1	1	1	
155	Adjusting Rod Upper	1	1	1	1	1	1	1	1	1	
155C	Adjusting Rod Lower	1	1	1	1	1	1	1	1	1	
156	Cotter Pin	3	3	3	3	3	3	3	3	3	
157A	Index Gear Bracket	1	1	1	1	1	1	1	1	1	
157B	Angle Bracket	1	1	1	1	1	1	1	1	1	
159	Toothed Segment	1	1	1	1	1	1	1	1	1	



## LIMITED SERVICE & WARRANTY POLICY

All **Little Wonder** products are guaranteed against defects in workmanship for a period of ONE YEAR FROM DATE OF PURCHASE when used for RESIDENTIAL SERVICE, NINETY DAYS FROM DATE OF PURCHASE FOR COMMERCIAL SERVICE. Any **Little Wonder** products or parts found to be defective within the warranty period are to be returned to our factory at Southampton, PA.

Transportation charges on parts and units submitted for replacement under this warranty must be borne by purchaser.

Engines for gas powered edgers are warranted separately by the engine manufacturer. Therefore, there are no warranties make, express or implied, for engines for gas powered edgers by **Little Wonder**.

THIS WARRANTY shall not be effective if the product has been the subject of misuse, negligence or accident or if the product has been repaired or altered outside of our Southampton factory in any respect which affects its condition or operation.

**Little Wonder** shall not be liable for any special indirect or consequential damages arising from defective equipment. Any implied warranty, including merchantability or fitness for a particular, shall not extend beyond the written period.

THIS WARRANTY shall only be effective if enclosed warranty card is properly filled out and returned to **Little Wonder**, Division of Schiller-Pfeiffer, Inc., 1028 Street Road, Southampton, PA 18966 at time of purchase.

## TROUBLE SHOOTING GUIDE

PROBLEM	POSSIBLE CAUSE	CORRECTIVE ACTION
A. Engine will not start	<ol style="list-style-type: none"> <li>1. Out of gasoline.</li> <li>2. Spark plug lead wire loose or disconnected</li> <li>3. Defective spark plug.</li> <li>4. Throttle control lever not in proper position.</li> <li>5. Engine flooded or flooding.</li> <li>6. Stale or contaminated gasoline.</li> </ol>	<ol style="list-style-type: none"> <li>1. Fill gasoline tank.</li> <li>2. Reconnect spark plug lead wire.</li> <li>3. Replace spark plug.</li> <li>4. Move throttle control lever to start position</li> <li>5. Start engine with choke fully open.</li> <li>6. Drain, clean tank and system and refill with fresh gasoline.</li> </ol>
B. Loss of power, hard starting.	<ol style="list-style-type: none"> <li>1. Spark plug lead wire loose.</li> <li>2. Defective spark plug.</li> <li>3. Carburetor out of adjustment.</li> <li>4. Air cleaner dirty.</li> <li>5. Air vents clogged or plugged.</li> </ol>	<ol style="list-style-type: none"> <li>1. Tighten spark plug lead wire</li> <li>2. Replace spark plug.</li> <li>3. Properly adjust carburetor.</li> <li>4. Clean and service air cleaner, (See the Briggs and Stratton or Kawasaki Operation and Maintenance illustrations.)</li> <li>5. Clean vent in gasoline tank cap and carburetor.</li> </ol>
C. Engine will not idle properly.	<ol style="list-style-type: none"> <li>1. Idle speed too slow.</li> <li>2. Spark plug gap incorrect.</li> </ol>	<ol style="list-style-type: none"> <li>1. Adjust carburetor idle speed or idle mixture.</li> <li>2. Set spark plug gap .030 (.76mm). For Briggs &amp; Stratton engine. For Kawasaki engine, the spark plug gap should be .6mm - .7mm.</li> </ol>
D. Engine runs hot or overheats.	<ol style="list-style-type: none"> <li>1. Oil level low.</li> <li>2. Engine cooling fins or baffles clogged, with dirt and debris</li> <li>3. Carburetor out of adjustment.</li> </ol>	<ol style="list-style-type: none"> <li>1. Fill crankcase to proper oil level.</li> <li>2. Clean and remove obstructions.</li> <li>3. Readjust carburetor.</li> </ol>
E. Control mechanisms for depth of blade will not function.	<ol style="list-style-type: none"> <li>1. Parts bent, distorted, worn out or missing.</li> </ol>	<ol style="list-style-type: none"> <li>1. Inspect control mechanism, and repair or replace damaged, worn out, or missing components.</li> </ol>